



FULLY ELECTRONIC CONTROLLED AC VOLTAGE STABILIZER AND POWER LINE CONDITIONER

MCT Series

Advanced Power Conditioning Technology
For Protection Of
Sensitive Electronic & Electrical Equipment



DESIGN FEATURES

Multi-Stage-Fail-Safe Design and Individual Stage Bypass Function

The cascading-transformers' arrangement is configured in such a way that each transformer together with its associated power switching device form an independent control-stage responsible for 'taking care' of a portion of the system's range of correction voltage.

In the event of electronic control failure on any single control-stage, it instantly activate an automatic bypass control to disable the affected control-stage and bypasses the cascading transformer. The bypass is a make-before-break switching ensuring that no interruption is caused to the output of the stabilizer.

The failure of one control-stage will only affect a certain portion of the stabilizer's range of correction voltage while the rest of the control-stages remain unaffected, avoiding total failure of the stabilizer.

No Sliding Electrical Contacts

In motor-driven-variatic technology, sliding contacts are the major contributors to the inherent wear and tear problems associated with the design. MCT stabilizer employs digital switching technology, eliminating the use of sliding contact, thereby achieving long term reliability.

High Efficiency

Motor-driven-variatic technology uses two sets of transformers; a sliding transformer (variatic) and a buck-boost transformer, contributing to almost all of the energy loss in the stabilizer. In contrast, the MCT stabilizer uses only one set of transformer (cascading transformer), as a result the energy loss is reduced by half.

Fast Correction Time

Depending on the application requirement, MCT stabilizer can be configured to attain its rated output voltage level in not more than 2 second responding to a full range of supply voltage variation.

Automatic Bypass Device

In the unlikely event of component failure that may result in the loss of output voltage regulation, MCT stabilizer is incorporated with automatic bypass device to switch the load directly to the supply, bypassing the stabilizer circuit, without interrupting the output power.

Modular Design For Easy Maintenance

The absence of complicated mechanical attachments and modular design offers ease of access to all internal component, considerably reduces downtime and cost of maintenance work.

Individual Phase Control

MCT three phase stabilizer is made up of three independent single phase stabilizers integrated into a single enclosure allowing 100% unbalance load or three individual single phase loads.

Intelligent Soft Start

When MCT stabilizer is powered up, the output voltage is made to follow the input to avoid under-voltage or over-voltage problem. The voltage correction function is initiated to regulate the output voltage only in 5 seconds after the supply power is connected to the stabilizer.

Cascading-Transformer Protection

A circuit break is incorporated between the AC supply and each cascading-transformer to protect against any excessive fault-current which might develop in the event of control-stage's failure.

TECHNICAL SPECIFICATIONS

Input

Single Phase	: 240V \pm 10%*
Three Phase	: 415V \pm 10%*
Frequency	: 50Hz / 60Hz \pm 5%

Output

Single Phase	: 240V \pm 2%*
Three Phase	: 415V \pm 2%*
Frequency	: 50Hz / 60Hz \pm 5%
Harmonic Distortion	: Nil
Efficiency	: Better than 98%
Load Power Factor	: 0.5 lagging / leading

** Other range of input and output voltages available on request.*

Environmental

Operating Temperature	: 0 to 45 °C
Relative Humidity	: 0 to 90% non-condensing
Audible Noise at	: <60dB 1meter

STANDARD FEATURES

Power On Indicator
Bypass Indicator
Output Voltmeter *
Output Ammeter *
Input Breaker *

OPTIONAL FEATURES

Start-up delayed output connection
Phase loss output disconnection
Precision output with \pm 1 volt accuracy
Manual by-pass activation.

MICROPROCESSOR CONTROLLED MULTI-CASCADING TRANSFORMER (MCT) STABILIZER AND POWER LINE CONDITIONER.

VOLTAGE FLUCTUATION PROBLEMS

All electrical appliances will function as designed only on electrical power with voltage levels which are kept within the required tolerances. When voltage levels fluctuate beyond an appliance's tolerable limits, they can cause over-voltage and under-voltage stresses, eventually damage the appliance.

A proven solution to these problems is the use of **Automatic Voltage Stabilizer**.

LIGHTNING STRIKES, SURGES AND HIGH FREQUENCY INTERFERENCE PROBLEMS

In situations where instability problems are added with other problems such as voltage spikes and surges caused by lightning strikes or other inductive loads and high frequency interferences generated by power electronic controlled loads, the use of stabilizers alone might not be able to solve the problems.

A **Power Line Conditioner** with added protections to the basic voltage stabilization will be a better solution.

STABILIZER

Cascading-transformers (**CAT**) are arranged in a cascade manner with their secondary windings connected in series with the power line between the input and output circuit. The primary windings of the transformers are connected to the mains supply via power-switching-devices (**PSD**) that are commanded by a microprocessor. The number of transformers in cascade connection depends on the input voltage range and the output voltage accuracy.

Each transformer can be commanded to feed a specific amount of subtracting or adding voltage into the power line via its secondary winding to decrease or increase the output voltage respectively. All switching operations are carried out on the primary side of the transformer without interrupting the secondary winding that constitutes part of the power line circuit.

A microprocessor based closed-loop feedback control circuit is used to monitor and maintain the output voltage tolerance. A portion of the output voltage is fed back to the microprocessor and compared with a preset reference that corresponds to the preset output voltage level to determine the amount of drift from the preset level. The microprocessor calculates the compensating voltage and activates the number of transformers to be switched into the circuit to restore the output to its rated voltage level.

All switching sequences are synchronized to the zero-crossings of the current waveform to eliminate switching transients. The switching operation can be configured to achieve very fast correction time to cater for specific application requirement.

POWER LINE CONDITIONER

Power line conditioners are stabilizers incorporated with voltage isolation or filter networks to suppress transient electrical disturbances such as voltage spikes and radio frequency interference (RFI).

To provide power conditioning, any one or more of the following enhancements could be incorporated as options depending on application requirements

- Isolation transformer
- Power line filter
- Lightning surge suppressor

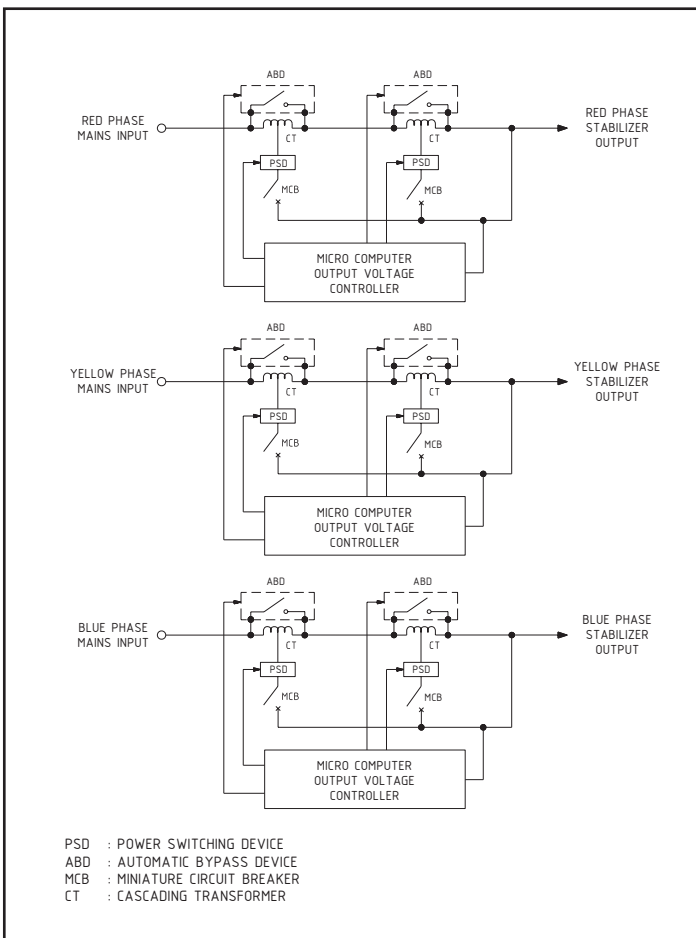

A THREE PHASE MCT STABILIZER FUNCTIONAL BLOCK DIAGRAM SHOWING A TWO-CASCADING-TRANSFORMER DESIGN.

MCT Series - 1 (Single) Phase 240V Input $\pm 10\%$ / Output $\pm 2\%$

Model	Rated Capacity (kVA)	Output current (A)	Input Breaker	Output Voltmeter	Output Ammeter	Weight kg	Dimension H x W x D mm
MCT - 3K	3	13	√	√	X	18	250 x 250 x 500
MCT - 4K	4	17	√	√	X	20	250 x 250 x 500
MCT - 5K	5	21	√	√	X	21	250 x 250 x 500
MCT - 7.2K	7.2	30	√	√	X	22	250 x 250 x 500
MCT - 10K	10	42	√	√	X	23	250 x 250 x 500
MCT - 12K	12	50	√	√	X	25	250 x 250 x 500
MCT - 15K	15	63	√	√	X	28	250 x 250 x 500
MCT - 20K	20	83	√	√	√	40	500 x 320 x 500
MCT - 24K	24	100	√	√	√	50	650 x 350 x 600
MCT - 30K	30	125	√	√	√	55	650 x 350 x 600

3MCT Series - 3 (Three) Phase 415V Input $\pm 10\%$ / Output $\pm 2\%$

Model	Rated Capacity (kVA)	Output current / phase (A)	Input Breaker	Output Voltmeter	Output Ammeter	Weight kg	Dimension H x W x D mm
3MCT - 5K	5	7	√	√	X	50	650 x 350 x 600
3MCT - 7.2K	7.2	10	√	√	X	54	650 x 350 x 600
3MCT - 10K	10	14	√	√	X	60	650 x 350 x 600
3MCT - 15K	15	21	√	√	X	72	650 x 350 x 600
3MCT - 20K	20	28	√	√	X	76	650 x 350 x 600
3MCT - 25K	25	35	√	√	X	90	650 x 350 x 600
3MCT - 30K	30	42	√	√	X	93	750 x 400 x 660
3MCT - 40K	40	56	√	√	X	96	750 x 400 x 660
3MCT - 45K	45	63	X	√	X	125	750 x 400 x 660
3MCT - 50K	50	70	X	√	√	130	1000 x 450 x 650
3MCT - 60K	60	84	X	√	√	135	1000 x 450 x 650
3MCT - 72K	72	100	X	√	√	140	1000 x 450 x 650
3MCT - 90K	90	125	X	√	√	143	1000 x 450 x 650
3MCT - 100K	100	139	X	√	√	146	1000 x 450 x 650
3MCT - 108K	108	150	X	√	√	225	1000 x 450 x 650
3MCT - 125K	125	174	X	√	√	235	1250 x 600 x 900
3MCT - 144K	144	200	X	√	√	300	1250 x 600 x 900
3MCT - 180K	180	250	X	√	√	310	1250 x 600 x 900
3MCT - 200K	200	278	X	√	√	315	1600 x 700 x 700
3MCT - 216K	216	300	X	√	√	330	1600 x 700 x 700
3MCT - 250K	250	347	X	√	√	350	1600 x 700 x 700
3MCT - 288K	288	400	X	√	√	-	TBA
3MCT - 324K	324	450	X	√	√	-	TBA
3MCT - 360K	360	500	X	√	√	-	TBA
3MCT - 396K	396	550	X	√	√	-	TBA
3MCT - 432K	432	600	X	√	√	-	TBA
3MCT - 504K	504	700	X	√	√	-	TBA
3MCT - 600K	600	833	X	√	√	-	TBA
3MCT - 648K	648	900	X	√	√	-	TBA
3MCT - 720K	720	1000	X	√	√	-	TBA
3MCT - 800K	800	1110	X	√	√	-	TBA
3MCT - 864K	864	1200	X	√	√	-	TBA
3MCT - 1000K	1000	1388	X	√	√	-	TBA

Dimension are subject to change without prior notice