

# LSS series



## STATIC TRANSFER SWITCHES

**Redundant Power Protection for Sensitive Electronic and Computer Equipment**

### APPLICATION

Static Transfer Switches (STS) are used to provide redundant AC power supply to sensitive electronic and computer equipment from two independent AC power sources.

Uninterruptible operation of critical load is assured by the STS's fast and seamless transfer of its output power supply between the two input power sources.

Transfer time from preferred source to alternative source is typically less than 5 milli-second and retransfer from alternative source to preferred source is virtually instantaneous.

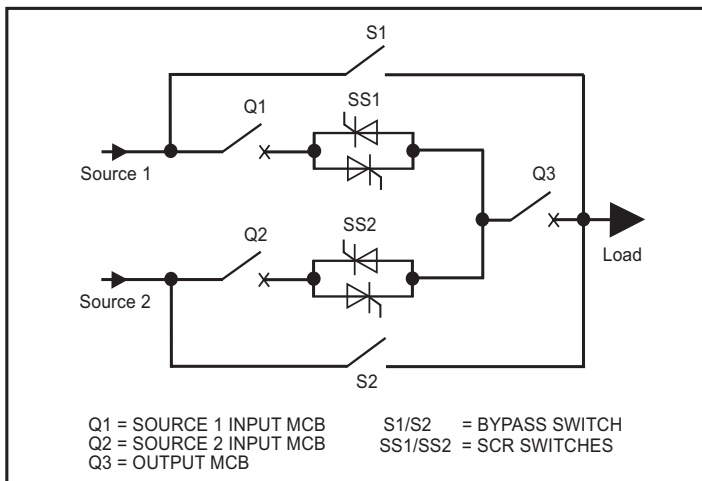

STS Single-Line Diagram

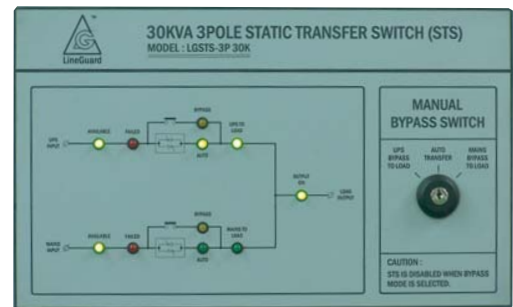

Control Panel and Mimic Panel

## DESIGN FEATURES

- Suitable for two non-parallel-connected synchronous or asynchronous independent AC sources.
- User defineable preferred source priority on either one power source.
- No hand-shaking is required between the two sources and the STS.
- User configureable automatic or manual retransfer from alternative source to preferred source.
- Manual maintenance bypass for disconnection of STS from circuit without load interruption.
- User-friendly control panel and informative monitoring mimic panel.

# STS OPERATION

## SCRs as switches

SCRs are used to form static switches to connect the power from the source to the load. One pole of static switch comprises of two bidirectional SCRs.

## Transfer Conditions

During normal operation, the load is connected to the preferred source while the alternative source is on active stand-by. Transfer of the load from the preferred source to the alternative source may be activated automatically or manually.

Transfer may be activated by:

- Preferred source unhealthy
- Loss of STS output due to internal fault.
- Manual change of preferred source

Transfer is not allowed in the event of:

- Alternative source unhealthy
- Output overcurrent

## Retransfer Conditions

Retransfer can be configured to be activated manually or automatically

Retransfer is not allowed in the in the event of:

- Preferred source unhealthy
- Output overcurrent

## Synchronous Transfer

When the two sources have phase error within the preset range, they are considered synchronised, the automatic transfer is immediate. A delay time of not more than 5 milli-second may be required to complete the transfer process due to the time required to sense the required condition.

Manual transfer / retransfer or automatic retransfer is instantaneous with time delay of not more than 0.1 milli-second.

## Asynchronous Transfer

Lack of synchronisation of the sources will force a time delay of 12 milli-second in the transfer operation. This is to ensure that the two unsynchronised sources are not short-circuited in the transfer process.

Time delay is also required in the retransfer from the alternative source to the preferred source.

## System Configuration

The single phase one pole and the three phase three pole STS have switches on the live lines only while the single phase two pole and the three phase four pole STS have additional switches included on the neutral line.

## Maintenance Bypass

As an option, maintenance bypass switches may be incorporated to the system. When maintenance is needed, the load can be bypassed to the preferred or the alternative source without interrupting the load to allow for service work to be carried out safely on the STS unit.

## Control Panel

Front mounted control panel allows user to access to all the necessary operations of the STS.

## Mimic Panel

Front mounted mimic panel with illustrative functional diagram and LED indicators provide informative display on the STS's operation and alarm status.

## TECHNICAL SPECIFICATIONS

<b>INPUT DATA</b>	
Voltage	240V single phase / 415V three phase +/-15%.
Frequency	50Hz +/- 6%.
<b>OUTPUT DATA</b>	
Nominal current	25A, 40A, 63A, 100A, 150A, 250A, 400A & 630A.
Configuration	Single phase one pole, single phase two pole, three phase three pole & three phase four pole.
Current crest factor	3.5
Overload capacity	120% - 60min. 300% - 5sec.
Short circuit capacity	At least 3000% for 20ms.
<b>SWITCHING DATA</b>	
Fault Triggered Transfer Time	Less than 5ms for synchronous sources. 12ms for asynchronous sources.
Automatic or Manual Transfer	Less than 0.1ms for synchronous sources. 12ms for asynchronous sources.
<b>ALARM DATA</b>	
Failure	LEDs and buzzer for overload, overtemperature, source 1 failure, source 2 failure and transfer blocked. Summary alarm common relay contact.
Disturbance	LEDs and buzzer for source 1 unhealthy, source 2 unhealthy, sources not synchronised, manual bypass on and automatic transfer switched off.
<b>ENVIRONMENT DATA</b>	
Ambient Temperature	0 to 40 C
Relative Humidity	0 to 90% non. condensing
Altitude	Below 1000 meter
Enclosure Type and Dimension	Available on request