



Model : Microtest 850sv
- Secondary Current Injection Test Equipment

Operation Instructions

This equipment should only be used by a well trained personnel instructed in the safe operation of the equipment under test. The following instructions are to be seen as an addition to each country or company's rules and regulations.

'ON + TIME' Function

1. Ensure correct connection of the current / voltage and sensing cables to the protective device under test.
2. Ensure that the **Microtest 850sv** is selected to 'OFF', before starting any test.
3. Connect stop conditions to the appropriate channels - dry or wetted contact. (Caution! - Connecting wetted contacts to the dry contact channel will cause irreversible damage to the device.)
4. Press 'SEL' button to select contact changeover type.
'NO' – Normally Open or 'NC' – Normally Close.
5. Press buttons 'RST' and 'I/O' together to enter SETUP and select current range.
0.000 A = 0-10A range
0.00 A = 0-30A range
0.0 A = 500 / 5A primary injection extension function
6. Turn on the **Microtest 850sv** output by pressing '▼' button, selecting – 'ON'.
7. Increase the current until alarm / trip occurs (pickup value).
8. Decrease the current until reset occurs (drop-off value).
9. Increase the current to 'n' times I > value.
10. Press '▲' button to – 'OFF' to turn off the **Microtest 850sv** output.
11. Turn on the **Microtest 850sv** output by pressing '▲', selecting – 'ON + TIME', the output will remain on until the protective device operates, 'TRIP' LED will light up.
12. The functional times are noted on the LCD.
13. The timer can be manually reset by selecting 'RST'. Otherwise, the timer will automatically reset when a new test is started.

'OFF + TIME' Function

1. This function is utilized for undervoltage protective devices.
2. Turn on the **Microtest 850sv** output by pressing '▼' button, selecting – 'ON'.
3. Increase the voltage to the protective device nominal value. *'TRIP' LED should light up. If not, press 'SEL' to change the contact changeover type.*
4. Turn off the **Microtest 850sv** output by pressing '▼', selecting – 'OFF + TIME', the output will turn off and the timer will start.
5. The functional times are displayed on the LCD when the protective device operates. *'TRIP' LED will turn off.*

IMPORTANT!

Each unit is equipped with a built-in high temperature protection device. Should the test equipment internal circuitry exceed 85 °C, the output source will automatically cut off. Output source will automatically resume when the control unit temperature decreases below 85 °C.

Model : Microtest 850sv

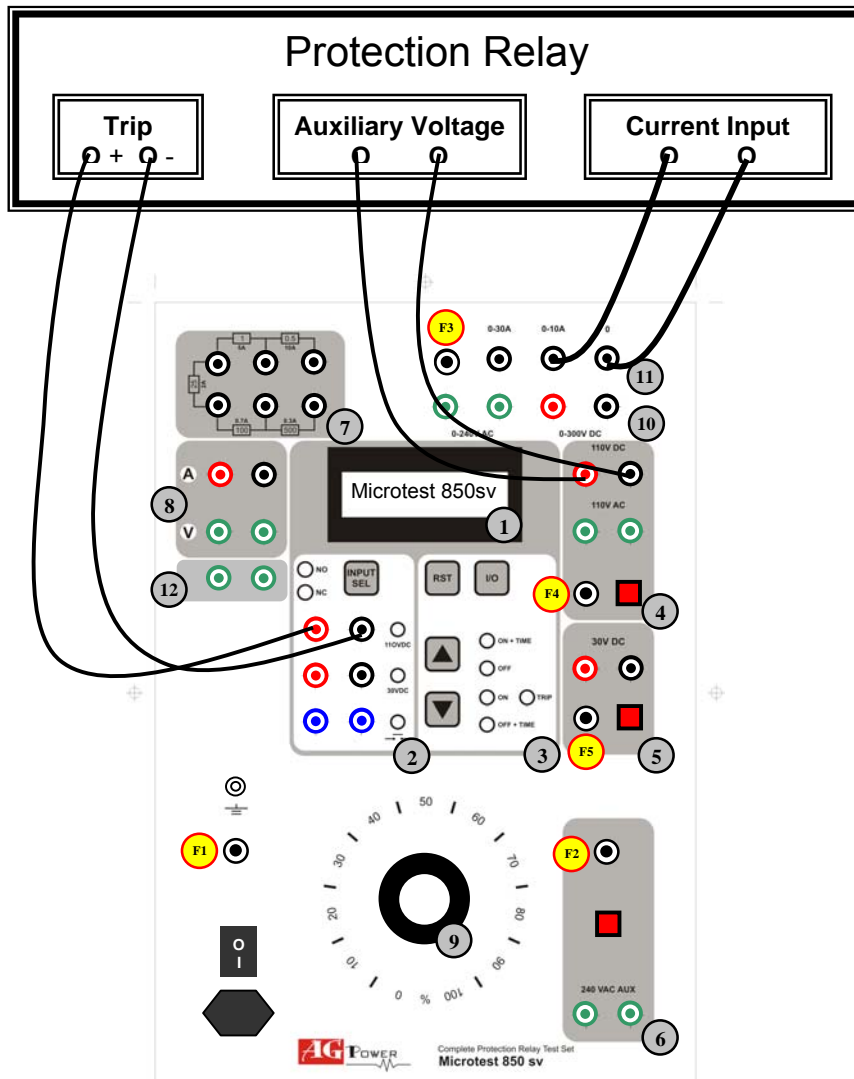

- | | |
|----------------------------------------------------------------------------------------------|---------------------------------|
| 1. LED Display | 6. 240 V ac Auxiliary Supply * |
| 2. STOP contact | 7. Resistor Set |
| 3. Control Module
'RST' – Timer Reset
'I/O/' – ON/OFF Timer
'Trip' – Trip Indicator | 8. Ammeter & Voltmeter Input |
| 4. 110 V dc & ac Auxiliary Supply * | 9. Variable Knob |
| 5. 30 V dc Auxiliary Supply * | 10. Voltage Source * |
| | 11. Current Source * |
| | 12. Non-Isolated Voltage Source |

* Voltage & Current source are isolated from mains supply.

Resettable Fuses	F1	F2	F3	F4	F5
Rating	3.0 A	0.5 A	2.0 A	0.5 A	1.0 A

IMPORTANT!

Always ensure equipment is adequately grounded and test leads are not damaged before starting test.

Model : Microtest 850sv

Current Injection Below 10 Ampere

For improved accuracy applicable only for current injection below 10 Ampere, setup should be carried out with the following presets.

1. Press both 'RST' and 'I/O' buttons together. Current display will now change from 0.00A to 0.000A.
2. **Injection is limited to 10 Ampere only!**
3. To return back to initial setup, press both 'RST' and 'I/O' buttons together. Current display will now change from 0.000A to 0.00A.

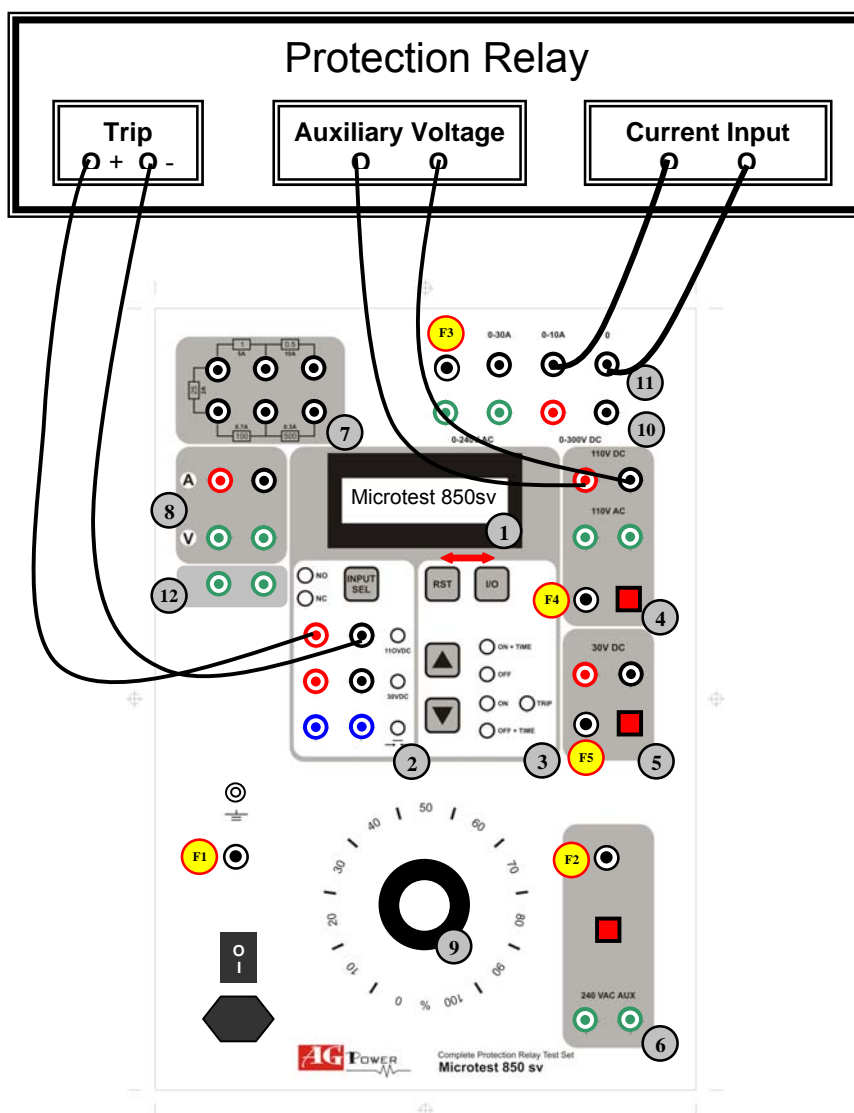

CAUTION!

Before disconnecting current / voltage cables from the protective device under test, turn the current / voltage adjustor knob to zero position, press button to 'OFF' and switch 'OFF' the test equipment.

Model : Microtest 850sv



TECHNICAL SPECIFICATIONS

Current Source

Range	Full-Load Current	Duty Cycle (ON circuit / OFF circuit)
0 – 5 A ac (80V)	10 A ac	10 min / 15 min
0 – 30 A ac (20V)	20 A ac	5 min / 15 min
	30 A ac	2 min / 15 min
	50 A ac	2 sec / 15 min

Voltage Source

Range	Full-Load Current	Duty Cycle (ON circuit / OFF circuit)
0 – 240 V ac	1 A ac (isolated)	15 min / 30 min
	2 A ac (non-isolated)	5 min / 15 min
0 – 300 V dc	1 A dc	15 min / 30 min

Fixed AC/DC Voltage Source – Unregulated

Range	Full-Load Current	Duty Cycle (ON circuit / OFF circuit)
240 V ac	0.5 A ac	15 min / 30 min
30 V dc	1.0 A dc	15 min / 30 min
110 V ac	0.5 A ac	30 min / 30 min
110 V dc	0.5 A dc	30 min / 30 min

Timer

Range	Accuracy	Functions
0.000 – 999.999	1 ms	ON + Timer Start OFF ON OFF + Timer Start

Unit is built with a triggerable START Command

Separate wet (Max. 250V AC/DC) and dry contacts available for triggering

Resistor Set

1 Ohm (5 A max.)	25 Ohm (2 A max.)	500 Ohm (0.3 A max.)
0.5 Ohm (10 A max.)	100 Ohm (0.7 A max.)	

Measurement

Current Range	0.000 – 1.999 A ac / ± 1.0% of metering 2.00 – 50.0 A ac / ± 1.0% of metering
Voltage Range	0 – 500 V ac / ± 1.0% of metering

General

Mains Voltage	240 VAC ± 10% , 50 / 60 Hz
Operating Temperature	0 – 55 °C , 5 - 95% R.H., non-condensing
Dimensions	32 cm x 23 cm x 29 cm
Weight	15 kg
Safety	The test set has been designed to incorporate EN 61010-1 specifications to Safety Class 1 & Installation Category 2

! Due to continuing development and improvements, specifications are subject to change without prior notice !
The manufacturer / distributor shall not be liable for any accidents or injuries caused by inappropriate or incorrect use of this test equipment.

Model : Microtest 850sv