

OPERATING PRINCIPLE

The automatic charger-inverter has four integral parts : an automatic battery charger, rechargeable battery, a power inverter and a change-over switch.

During normal operation when the mains power is available, the rechargeable battery is always kept at full-charge condition by the automatic battery charger. The change-over switch connects the mains power to the load.

In the event of a mains power failure, the power inverter changes the battery power to electric power quite similar to the mains power. The change-over switch connects the power to the load.

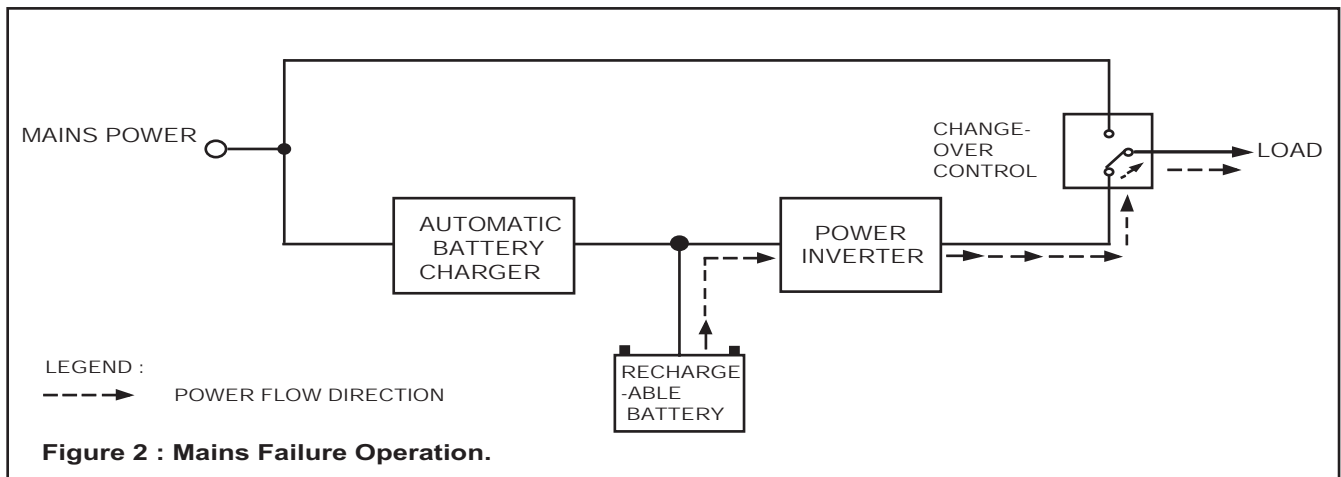
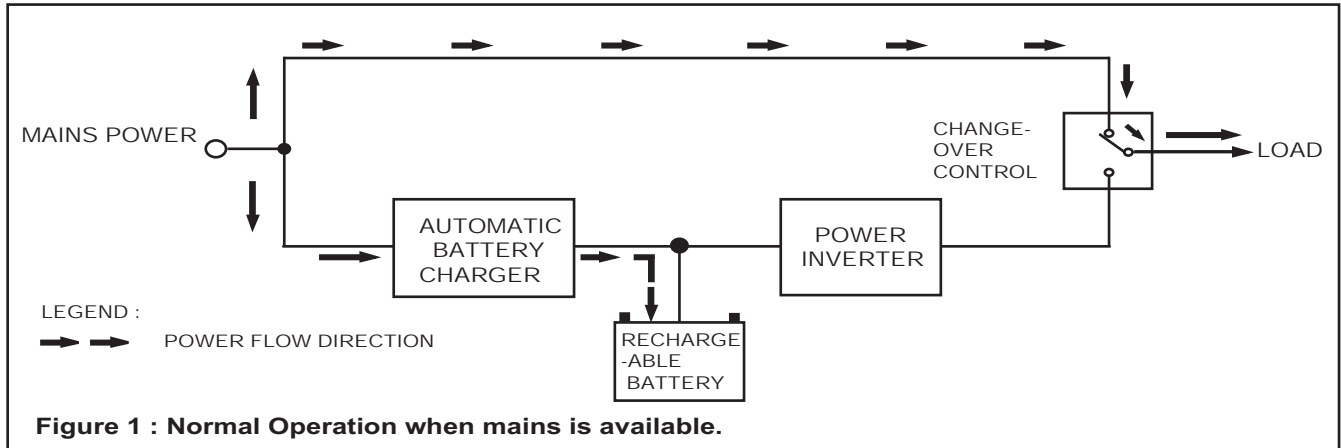

TECHNICAL SPECIFICATION

Model	Output Power	Battery Voltage	Battery Discharge	Battery Capacity	Charge Current	Dimension HxWxD(mm)	Weight (KG)
LCI 250W	250W	12V	25amps	150Ah	20amps	235X220X350	14
LCI 500W	500W	12V	50amps	300Ah	40amps	235X220X350	17